

M8x0.75 / x1

Stroke 5mm

200%

ZIMMER INDUSTRIAL-SHOCK ABSORBER
WITH **2,0** TIMES OF ENERGY ABSORPTION

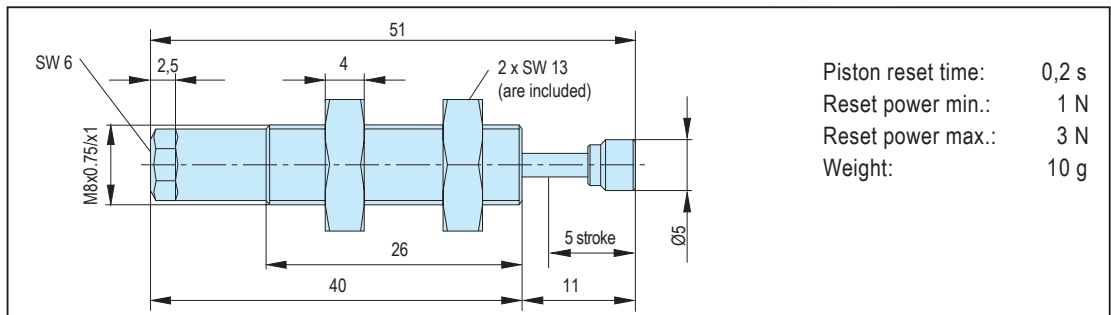

Piston reset time: 0,2 s
Reset power min.: 1 N
Reset power max.: 3 N
Weight: 10 g

Power Stop

construction size/ order number	energy absorption/ per stroke Nm	energy absorption/ per hour Nm/h	stroke mm	impact speed		actual mass*	
				min m/s	max	max kg	min
M8x0.75S	3,5	12.600	5	2,0	3,5	1,7	0,6
M8x0.75M	3,5	12.600	5	1,2	2,5	4,8	1,1
M8x1S	3,5	12.600	5	2,0	3,5	1,7	0,6
M8x1M	3,5	12.600	5	1,2	2,5	4,8	1,1

*Actual mass as comparative value to conventional industrial shock absorber

Accessories

order number: MAH8x0.75, MAH8x1
arresting sleeve
stainless-steel

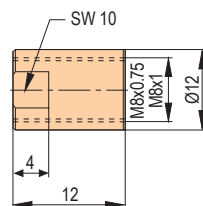

order number:
MKK8
head
plastic

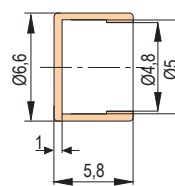

cooler nut (Aluminium)
on request