

M45x 1.5

Stroke 25mm

280%

ZIMMER INDUSTRIAL-SHOCK ABSORBER
WITH **2,8** -TIMES OF ENERGY ABSORPTION



Available as MOA45
and EmergencyStop I-Class
(see page 9)

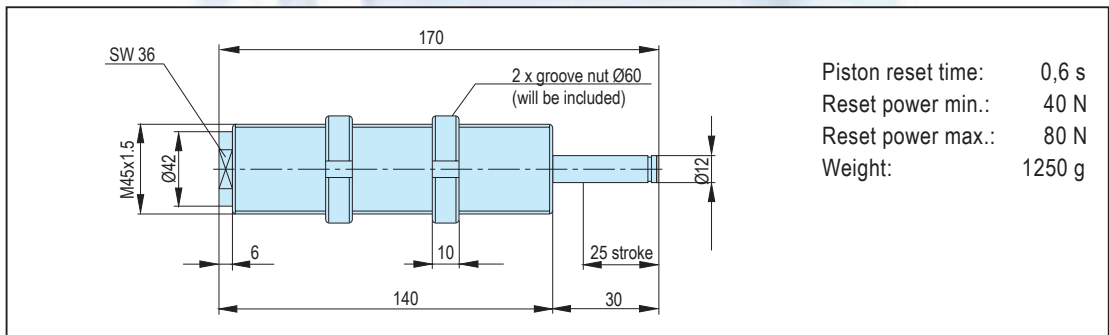

construction size/ order number	energy absorption/ per stroke	energy absorption/ per hour	stroke mm	impact speed		actual mass*	
	Nm	Nm/h		min	max	max	min
M45x1.5S	650	150.000	25	1,4	3,5	663	106
M45x1.5M	650	150.000	25	0,6	1,6	3611	508
M45x1.5H	650	150.000	25	0,2	0,7	32500	2653

construction size/ order number	energy absorption/ per stroke	energy absorption/ per hour	stroke mm	impact speed		actual mass*	
	Nm	Nm/h		min	max	max	min
M45x1.5SN	1500	-	25	1,4	3,5	1531	245
M45x1.5MN	1500	-	25	0,6	1,6	8333	1172
M45x1.5HN	1500	-	25	0,2	0,7	75000	6122

*Actual mass as comparative value to conventional industrial shock absorber

