

M33x 1.5

Stroke 30mm

300%

ZIMMER INDUSTRIAL-SHOCK ABSORBER
WITH **3,0** -TIMES OF ENERGY ABSORPTION



Available as MOA33
and EmergencyStop I-Class
(see page 9)

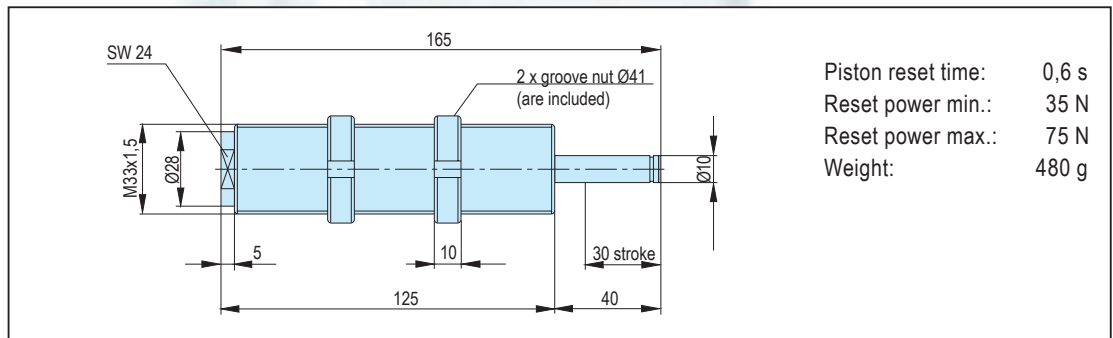

Power Stop

construction size/ order number	energy absorption/ per stroke Nm	energy absorption/ per hour Nm/h	stroke mm	impact speed		actual mass*	
				min m/s	max	max kg	min
M33x1.5S	320	120.000	30	1,4	3,5	327	52
M33x1.5M	320	120.000	30	0,6	2,0	1778	160
M33x1.5H	320	120.000	30	0,2	0,8	16000	1000

Emergency Stop

construction size/ order number	energy absorption/ per stroke Nm	energy absorption/ per hour Nm/h	stroke mm	impact speed		actual mass*	
				min m/s	max	max kg	min
M33x1.5SN	900	-	30	1,4	3,5	918	147
M33x1.5MN	900	-	30	0,6	2,0	5000	450
M33x1.5HN	900	-	30	0,2	0,8	45000	2813

*Actual mass as comparative value to conventional industrial shock absorber

Accessories

