

M25x 1.5L

Stroke 40mm

200%

ZIMMER INDUSTRIAL-SHOCK ABSORBER
WITH **2,0**-TIMES OF ENERGY ABSORPTION

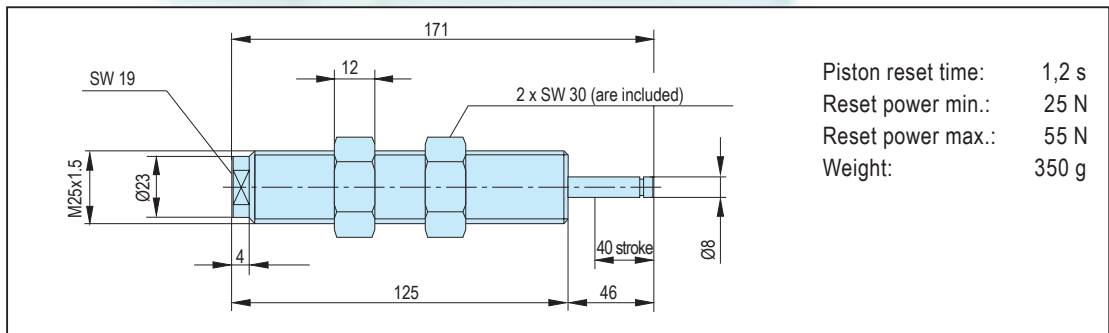

Piston reset time: 1,2 s
Reset power min.: 25 N
Reset power max.: 55 N
Weight: 350 g

Power Stop

construction size/ order number	energy absorption/ per stroke	energy absorption/ per hour	stroke mm	impact speed		actual mass*	
	Nm	Nm/h		min	max	max	min
M25x1.5LS	300	135.000	40	2,0	4,0	150	37,5
M25x1.5LM	300	135.000	40	0,6	2,2	1666	124

Emergency - Stop

construction size/ order number	energy absorption/ per stroke	energy absorption/ per hour	stroke mm	impact speed		actual mass*	
	Nm	Nm/h		min	max	max	min
M25x1.5LSN	750	-	40	2,0	4,0	375	94
M25x1.5LMN	750	-	40	0,6	2,2	4167	310

*Actual mass as comparative value to conventional industrial shock absorber

Accessories

cooler nut (Aluminium)
on request

order number: MAH25x1.5
arresting sleeve
stainless steel

order number:
MKK25/MKS25
head
plastic/steel

order number: MRA25x1.5L
lock air adapter/
bolt pre-supporting

