

# M14x 1 / M14x1.5

Stroke 12mm

# 280%

ZIMMER INDUSTRIAL-SHOCK ABSORBER  
UP TO **2,8**-TIMES OF ENERGY ABSORPTION

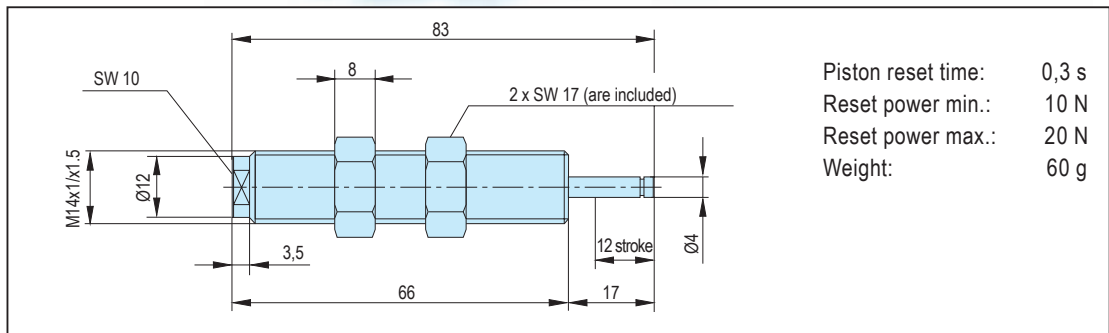

Piston reset time: 0,3 s  
Reset power min.: 10 N  
Reset power max.: 20 N  
Weight: 60 g

## Power Stop

**NEW**  
**NEW**

construction size/ order number	energy absorption/ per stroke Nm	energy absorption/ per hour Nm/h	stroke mm	impact speed		actual mass*	
				min m/s	max m/s	max kg	min kg
M14x1W	16	26.000	12	2,0	5,0	8	1,3
M14x1S	31	50.000	12	2,0	5,0	16	2
M14x1M	31	50.000	12	1,2	2,2	43	13
M14x1H	31	50.000	12	0,2	1,4	1550	32
M14x1.5W	16	26.000	12	2,0	5,0	8	1,3
M14x1.5S	31	50.000	12	2,0	5,0	16	2
M14x1.5M	31	50.000	12	1,2	2,2	43	13
M14x1.5H	31	50.000	12	0,2	1,4	1550	32

\*Actual mass as comparative value to conventional industrial shock absorber

## Accessories

